

Likorall 242 ES

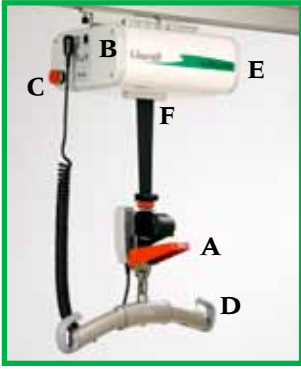

Likorall 242 ES with new electronics, prepared for IR-control and rail switch control.

Likorall 242 ES



A unique safety system

- A. Mechanical emergency lowering (not with R2R). A reliable safety feature if the motor stops for any reason.
- B. Battery "back-up" for emergency lowering if electricity is interrupted.
- C. Emergency stop button.
- D. Safety catches on the sling bar prevent slings from accidentally unhooking.
- E. Safety drum with speed control and mechanical stops for control of (highest/lowest) lifting span.
- F. SSP, Safety squeeze protection.



Room-to-room

Likorall 242 ES R2R makes it possible to move users between rail systems in two rooms that do not have interconnecting rails, without cutting an opening above the door.

Building Heights

The diagram shows the different measurements (building heights) in a complete Likorall rail installation. Some of the numbers depend on type of installation.

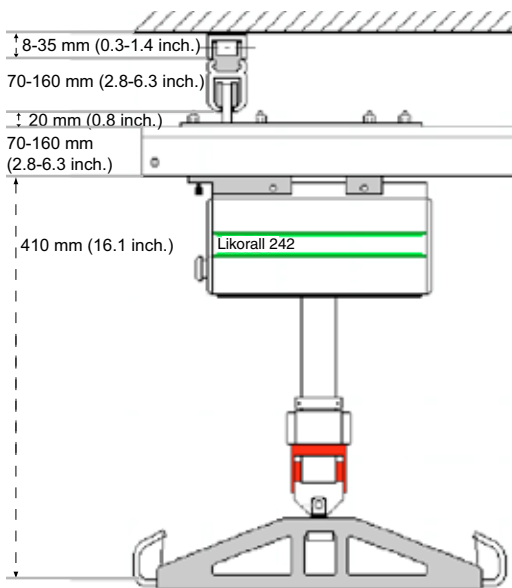

Battery charging

To recharge Liko's batteries, simply plug the hand-control into the wall-mounted battery charger which is also approved for use in bathrooms. A fully charged battery operates Likorall for approximately 50 lifts.

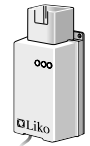

Prod.no

- 3122005 Likorall 242 ES, natural
- 3122006 Likorall 242 ES, white
- 3122007 Likorall 242 ES R2R, natural
- 3122008 Likorall 242 ES R2R, white

Transfer motor for Likorall 242 ES



Wide range of accessories

Likorall and Liko slings and accessories allow one person to easily perform otherwise demanding, and heavy lifts. Liko offers a range of accessories, creating solutions to any lifting problem encountered in healthcare.

Technical Specifications

Capacity: 200 kg (440 lbs)
Lifting Speed: 5 cm/s (2 inch./s)
Liftspan: 210 cm (83 inch.)
Motor: 24 V, 10A

Em. Lowering: Electrical and mechanical
Batteries: Two rechargeable, valve regulated lead-acid batteries, 12V 2,6 Ah
Battery Charger: Fully automatic shutdown/restart



Likorall 242 ES is classified as a medical technical device, according to MDD 93/42/EEC. Likorall 242 ES complies with the requirements according to IEC 60601-1, IEC 60601-1-2, EN ISO 10535, UL-2601-1 and CAN/CSA C22.2 No.606.1. Maximum load: 200 kg, 440 lbs.

Design and Quality by Liko in Sweden.

Liko is quality-certified in accordance with ISO 9001 and its equivalent for the medical device industry, ISO 13485.

Liko is also certified in accordance with environmental standard ISO 14001.



www.liko.com

Manufactured by:

Liko AB
 Nedre vägen 100
 975 92 Luleå
 Sweden
 info@liko.se

Local representative in UK

Hill-Rom Limited
 Clinitron House, Ashby Park
 Ashby de la Zouch,
 Leicester LE65 1JG
 Tel: 01530 411000
 Fax: 01530 411555
 info@liko.co.uk

To find your local Liko representative,

please visit www.liko.com or call
 +46 (0)920 47 47 00



A Hill-Rom Company